

NO	DESCRIPTION	DIMENSION	QT'Y	REMARK
1	FAN	3øX200VX50WX4P	12EA	TP-13B-1.
2	EVAPORATOR	D.X/Coil 1/2" 16R*16S*1850EL 10PITCH		
3	CONTROL BOX	3øX220VX60HZ	1EA	DAEWOOINDS
4	INVERTER	3øX200VX3KW	1EA	MOSCON-E7
5	DOOR S/W	DC12~24V	2EA	PS17-5 DM/PM10-U
6	Defros HEATER	380VX1.0KW	18EA	18KW
7	TRANS FORMER	380V-220V/5KW	1EA	신우전기산업
8	IN SIZE	800(W)X1750(H)X2000(D)	1EA	
9	PIR-URETHANE PANEL	PANES304*125T	1SET	
10	DISTRIBUTOR	5/16"X10HLOE	1EA	
11	EXP. V/V.	TES12-07(N),TES12-06(N),TES12-5(B)	3EA	DANFOSS
12	SOL. V/V	EVR10 5/8"	3EA	DANFOSS
13	REFRIGERANT PIPE	1 1/2" 7/8"	1SET	
14	DOOR	880(w)x1790(h)	2EA	

15	POWER SOURCE	380V*3PH*60Hz
16	TOTALL POWER	18.0KW

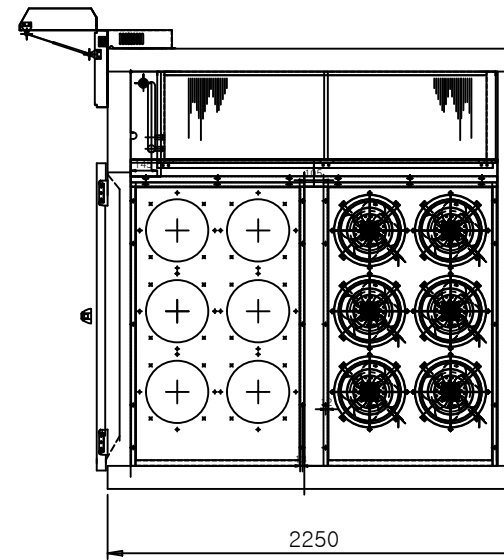
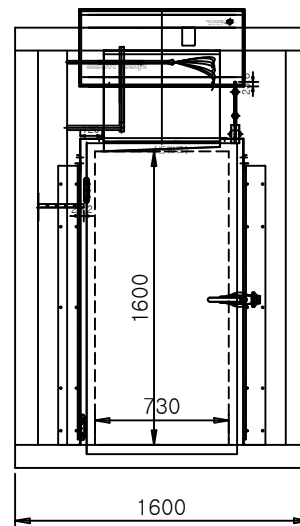
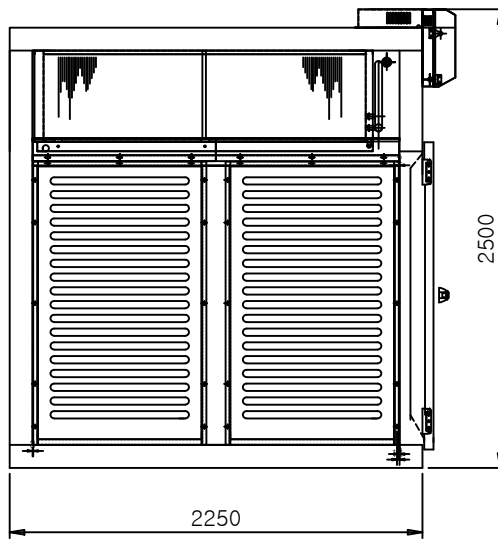

					<b>TITLE</b> 실내기	
SCALE	none	DESIGN	DRAWN	CHECK	APPR	<b>PROJECT TITLE</b> DF-200B
UNIT	mm					
THIRD ANGLE PROJECTION		DATE	20200605	SIGN	kim	<b>DWG NO</b> DF-200T
SYMBOL	REASONABLE	DATE		SIGN	CHECK	<b>REV</b> : 0