

NO	DESCRIPTION	DIMENSION	QTY	REMARK
1	FAN	3#X200VX50WX4P	18EA	TP-13B-1.
2	EVAPORATOR	D.X/Coil 1/2" 18R*15S*2550EL 10PITCH		
3	CONTROL BOX	3#X220VX60HZ	1EA	REFCYCLE
4	INVERTER	3#X200VX3KW	1EA	MOSCON-E7
5	DOOR S/W	DC12~24V	2EA	PS17-5 DN/PA10-U
6	Defros HEATER	380VX1.3KW	18EA	23.4KW
7	FRONT PANEL	VER1.0	1EA	daewoo
8	IN SIZE	800(W)X1750(H)X2830(D)	1EA	
9	PIR-URETHANE PANEL	SUS304*125T	1SET	
10	DISTRIBUTOR	5/16"X18HLOE	1EA	
11	EXP. V/V	TES55-11(N), TES55-10(N), TES55-11(변저)	3EA	DANFOSS
12	SOL. V/V	EVR10, 5/8"	3EA	DANFOSS
13	REFRIGERANT PIPE	2 1/2" * 7/8"	1SET	
14	DOOR	740(w)x1650(h)	2EA	
15	POWER SOURCE	380V*3PH*60Hz		
16	TOTAL POWER	26.0KW		

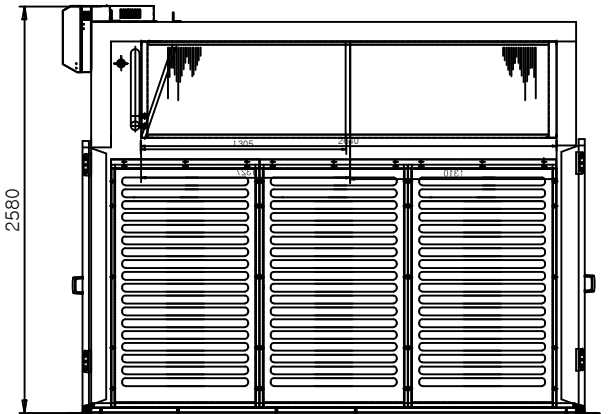
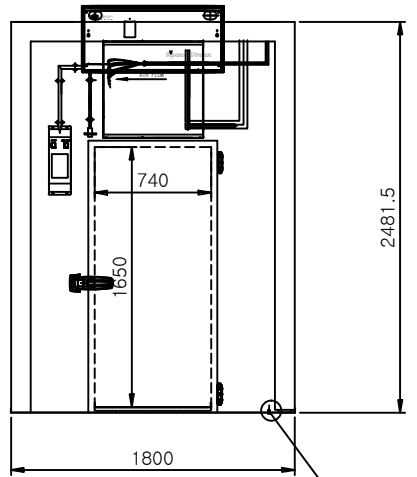
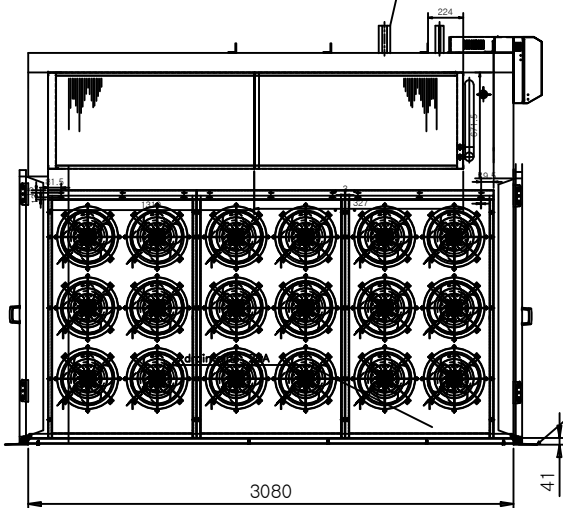

주·식·회·사 대우인더스트리 DAEWOO INDUSTRY CO.,L.DT			TITLE 초급속동결기 실내기		
SCALE	none	DESIGN	DRAWN	CHECK	PROJECT TITLE DF-300T
UNIT	mm				DWG NO DF-300T
THIRD ANGLE PROJECTION			in PARK		REV : 0

SYM	REASONABLE	DATE	SIGN	CHECK	APPR
		200105		kim	